

# Simple type

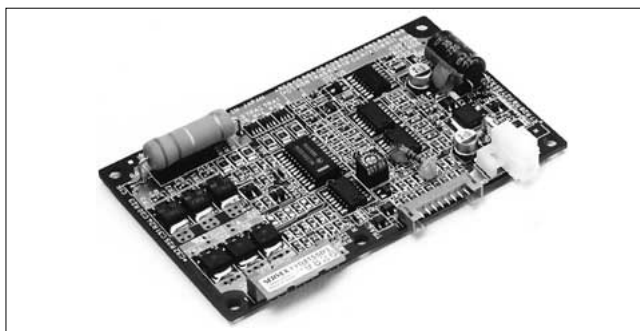

## ■Specification

Model on motor	Plain shaft type	<b>FY6S6-D3</b>		<b>FY8S15-D3</b>		
	Pinion shaft type	<b>FY6PF6N-D3</b>		<b>FY8PF15N-D3</b>		
Model on driver	Plain shaft type	<b>FYD66SD3</b>		<b>FYD815SD3</b>		
	Pinion shaft type					
Rated voltage	V(DC)	24		24		
Rated output	W	6		15		
Speed range	r/min	200~2500		200~2500		
Rated torque	mN • m	39		98		
	oz • in	5.6		14		
Rated speed	r/min	1500		1500		
Speed setting method		①Speed setting by external speed setter(Sold separately : Model code Q-R10KB)				
		②Speed setting by external voltage supply 0~10V				
Speed setting	(r/min)/V	300±5%				
Speed variation		Against load	±1%	0~rated torque at rated voltage and speed		
		Against voltage	±1%	DC24V±10% at rated speed, no load		
		Against temperature	±3%	20±20°C at rated voltage and speed, no load		
Input and output signal		Input	RUN, BRAKE, F/R IN H : Open collector L : GND(0~0.8V)			
		Output	ALARM OUT, HU OUT, HV OUT H : Open collector DC30V MAX. L : 0~0.8V 10mA MAX.			
pulse rate	Pulse/Revolution	5		5		
Current	Rated (Ave.)	A	0.7 MAX.		1.4 MAX.	
	MAX. (Peak)		2.8 MAX.		5 MAX.	
Protection		Over load protection When a load exceeding rated torque is applied to motor for more than about 5sec. Stop motor and output "L" from "ALARM" In case of alarm reless, disconnect power supply for more than 1min.				
Others		Operation temperature 0~40°C(no condensation) continuous duty. The motor flange surface tempo must be 80°C MAX. (Ambient temperature 40°C without heat sink) Motor dielectric strength Withstad for 1min. under AC500V 50Hz(Between case and coil) Motor insulation resistance 10MΩMIN. (Between case and coil DC500V tester.)				
Gear ratio	Speed(r/min)		Applicable MAX. Torque for gearheads			
	at 200r/min	at 2500r/min	<b>6H□FBN</b>		<b>8H□FBN</b>	
			mN • m	oz • In	mN • m	oz • In
5	40	500	160	22	390	56
15	13	167	470	67	1200	170
25	8	100	720	100	1800	250
30	6.7	83	850	120	2100	290
50	4	50	1400	190	3100	440

- □: rotation of gear head output shaft becomes reverse direction of motor's.

# BRUSHLESS DC MOTOR & SPEED CONTROL DRIVERS

# FYD Series DC24V

## ■Torque-speed/Current (TYP.) characteristics

### (FY6S6-D3+FYD66SD3)

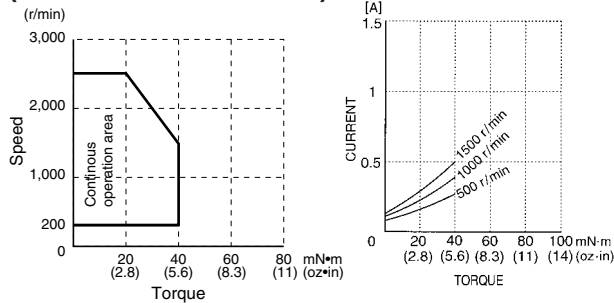

## ■Motor outlines(Plain shaft type)

Unit : mm (inch)

### FY6S6-D3

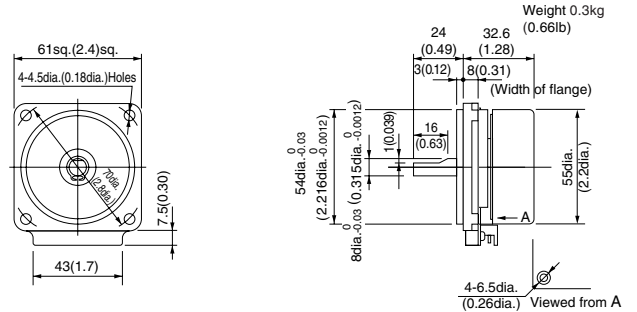

### (FY8S15-D3+FYD815SD3)

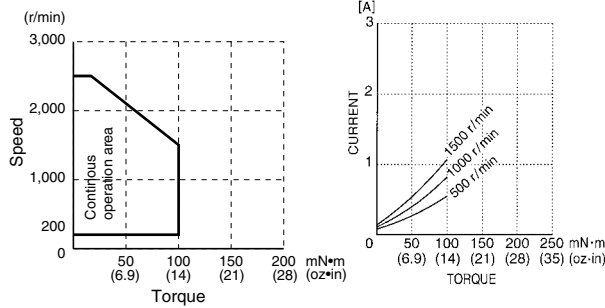

### FY8S15-D3

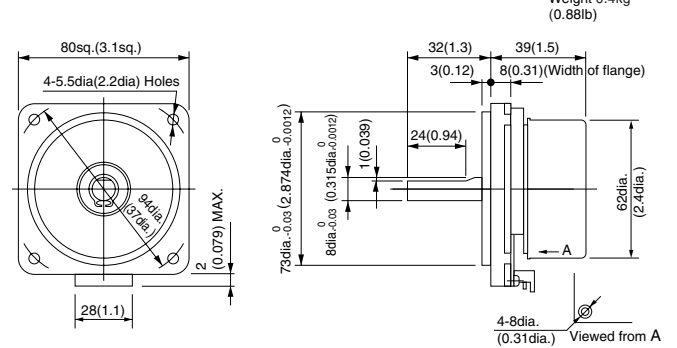

## ■Motor(Pinion shaft type)+gearhead outlines

### FY6PF6N-D3+ 6H □ FBN

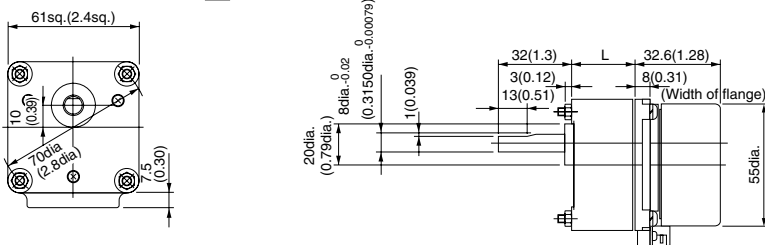

### FY8PF15N-D3 + 8H □ FBN

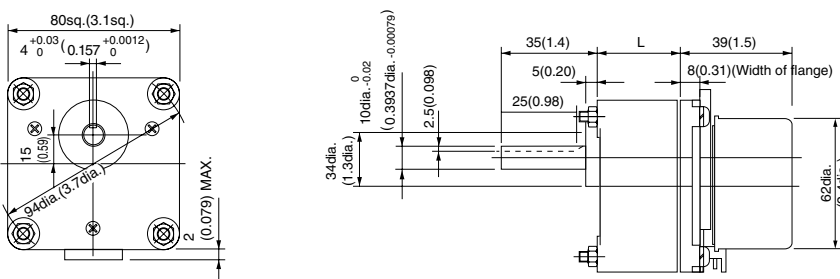

L(Gear head length)•Weight•Screw(Accessory)

Gear ratio	L mm(In.)	Weight Kg(lb)	Screw
1/5~1/15	32(1.3)	0.4(0.88)	M4X50(2.0)
1/25~1/50	42(1.7)	0.4(0.88)	M4X60(2.4)

L(Gear head length)•Weight•Screw(Accessory)

Gear ratio	L mm(In.)	Weight Kg(lb)	Screw
1/5~1/15	30(1.2)	0.5(1.1)	M5X50(2)
1/25~1/50	40(1.6)	0.6(1.3)	M5X60(2.4)

# Input & output terminals and wiring diagram

Item	Pin No.	Symbol	Input or Output	Function	Standard • Condition	
Power Supply	1	VM	Input	Power supply positive for drive	DC24V±10%	
	2	P.GND	—	Power supply GND for driver		
I/O	1	HU OUT	Output	5 pulse/revolution (Hall signal) *1	H : Open collector DC30V MAX. L : 0~0.8V 10mA MAX.	
	2	HV OUT	Output			
	3	ALARM OUT	Output	H : Normal operation L : Protective function operates		
	4	VR	Output	Power supply positive for external speed setter		
	5	VS	Input	Speed setting signal positive		
	6	GND	—	Speed setting signal GND		
	7	GND	—	GND for I/O signal		
	8	F/R IN	Input	H : CCW L : CW (Viewed from motor output shaft end)		
	9	BRAKE	Input	H : Brake releases L : Brake operates		H : Open collector L : 0~0.8V
	10	RUN	Input	H : Motor stops L : Motor rotates		

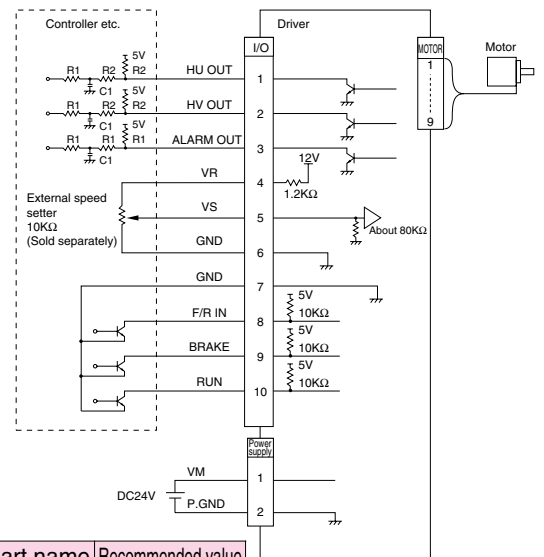

Part name	Recommended value
R1	4.7KΩ
R2	1KΩ
C1	0.01μF

\*1 "HU OUT" signal and "HV OUT" signal are shown below.  
Motor rotation (viewed from motor output shaft end)

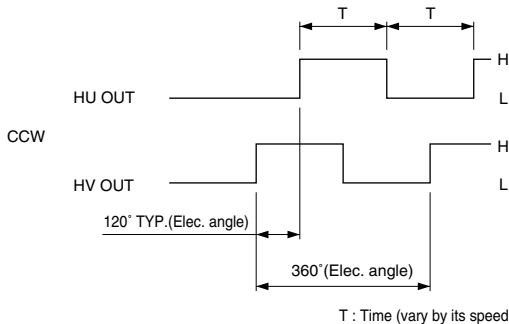
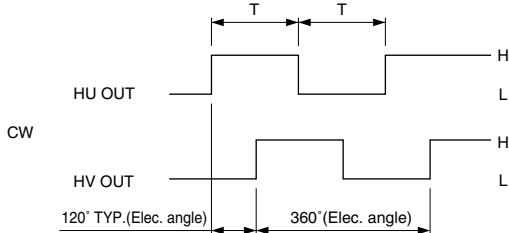

When input signal is H, input signals (RUN, BRAKE, F/R IN) should be input by open collector. If 5V is input, it will become the cause of wrong operation. Noise of output signals (ALARM OUT, HU OUT, HV OUT) should be removed by a filter as shown in fig. Setting of filter constant should be done by confirming the noise level referring to the recommended constant. At this time, be careful that signal delays if the values of resistance and/or capacitor are big though it becomes better to kill noise. Specially, for HU OUT, HV OUT, setting should be done with attention to filter constant because pulse width is narrow.

## Control sequence

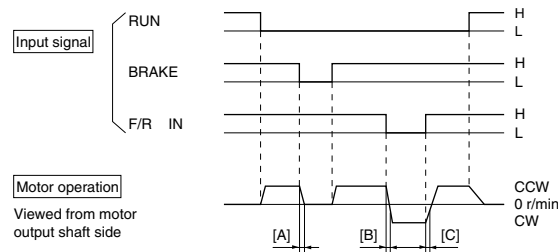

[Notes for "BRAKE" operation and during the rotation direction changing]  
"BRAKE" (Above [A] period) should be operated, within the "SPEED CONTROL RANGE". If it is used differently from above, it may cause fire or failure. Also, be careful that "VM" terminal voltage happens to rise up to about 30V according to the condition of use during the rotation direction changing (Above [B] and [C] periods). (Brake operation : Short brake.)

## Speed setting

Fig.1 Speed setting by external speed setter

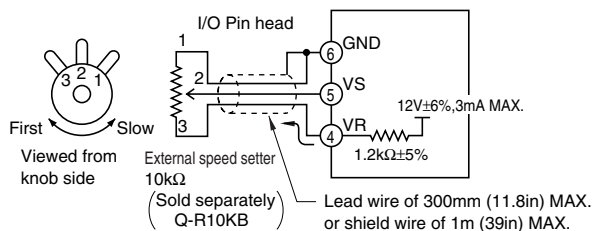
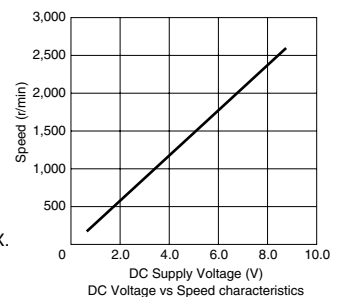
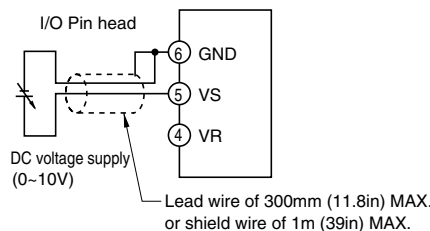

Fig.2 Speed setting by external voltage supply



Item	Setting Method
Speed setting by external speed setter (sold separately)	Connect as shown in Fig.1 and set by external speed setter. Use variable resistor 10[KΩ] as external speed setter.
Speed setting by external voltage supply	Connect as shown in Fig.2 and set speed by external voltage supply.

By these method, it is possible to set a speed at outside of Speed range. But it must be out of our product warranty.

## ■ Driver outline

Unit : mm (inch)

### FYD66SD3, FYD815SD3

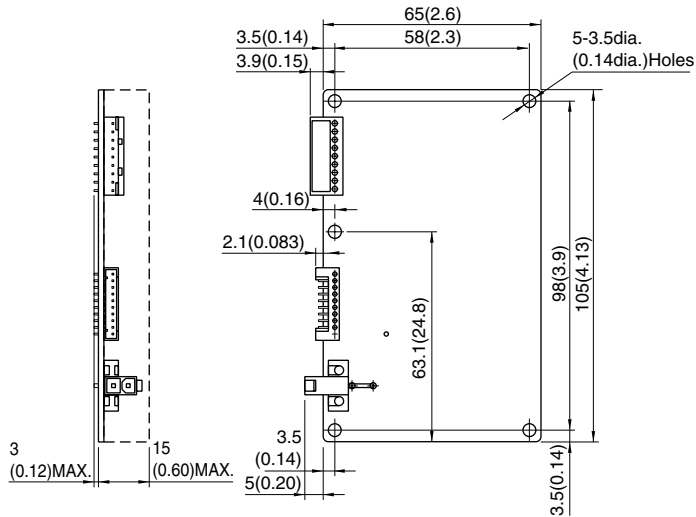

Weight 0.1kg  
(0.22Lb)

## ■ Protection

Item	Protection		Alarm Release
	Setting	Operation	
Overload Protection	When the load exceeding rated torque is applied to motor for more than about 5 sec.	Motor is stepped and "ALARM" outputs "L"	Disconnect power supply for more than 1 minute.

Do not measure/judge by this operation whether the motor is overloaded or not.

## ■ Accessory

Unit : mm (inch)

I/O cable

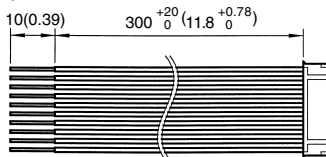

Connection guide

Pin No.	Name	Lead wire color	Lead wire
1	HU OUT	Brown	UL3265 AWG28
2	HV OUT	Red	
3	ALARM OUT	Orange	
4	VR	Yellow	
5	VS	Green	
6	GND	Blue	
7	GND	Purple	
8	F/R IN	Gray	
9	BRAKE	White	
10	RUN	Black	

Power supply cable

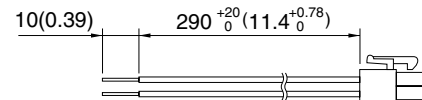

Connection guide

Pin No.	Name	Lead wire color	Lead wire
1	VM	Red	UL1430
2	P. GND	Black	AWG22

Motor cable

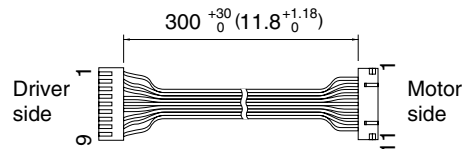

Connection guide

Motor side connector Pin No.	Driver side connector Pin No.	Name	Lead wire color	Lead wire
1	1	Coil U	Brown	UL1007 AWG24
2	-	-	-	-
3	2	Coil V	Red	UL1007 AWG24
4	-	-	-	-
5	3	Coil W	Orange	UL1007 AWG24
6	4	-	Yellow	
7	5	HW	Green	
8	6	HV	Blue	
9	7	HU	Purple	
10	8	GND	Gray	
11	9	12V	White	

## ■ Connector model code

Item	Driver or motor side	Pin head model code on driver or motor	Connector model code on cable		Maker
			Housing	Contact (reel)	
I/O connection	Driver	IL-S-10P-S2L2-EF	IL-S-10S-S2C2-S	IL-S-C2-S-10000	JAE
Power supply connection	Driver	5566-02A	5557-02R	5556T	MOLEX
Motor connection	Driver	IL-G-9P-S3T2-E	IL-G-9S-S3C2	IL-G-C2-SC10000	JAE
	Motor	IL-G-11P-S3L2-E	IL-G-11S-S3C2	IL-G-C2-SC-1000	

**Motor/Driver/Cable/Rotor cover model code table** Unit : mm (inch)

	Motor model code	Driver model code	Power supply cable model code	Motor cable model code	I/O Cable model code	Rotor cover model code	
<b>FY series</b>	<b>Simple driver</b>	FY6S6-D3	FYD66SD3	FED-CNSL03 300 (11.8)	FED-CNML03 300 (11.8)	FYD-CNBL03 300 (11.8)	F-RC630
				FED-CNSL05 500 (19.7)	FED-CNML05 500 (19.7)	FYD-CNBL05 500 (19.7)	
				FED-CNSL10 1000 (39.4)	FED-CNML10 1000 (39.4)	FYD-CNBL10 1000 (39.4)	
		FY6PF6N-D3	FYD66SD3	FED-CNSL03 300 (11.8)	FED-CNML03 300 (11.8)	FYD-CNBL03 300 (11.8)	F-RC630
				FED-CNSL05 500 (19.7)	FED-CNML05 500 (19.7)	FYD-CNBL05 500 (19.7)	
				FED-CNSL10 1000 (39.4)	FED-CNML10 1000 (39.4)	FYD-CNBL10 1000 (39.4)	
	FY8S15-D3	FYD815SD3	FED-CNSL03 300 (11.8)	FED-CNML03 300 (11.8)	FYD-CNBL03 300 (11.8)	F-RC837	
			FED-CNSL05 500 (19.7)	FED-CNML05 500 (19.7)	FYD-CNBL05 500 (19.7)		
			FED-CNSL10 1000 (39.4)	FED-CNML10 1000 (39.4)	FYD-CNBL10 1000 (39.4)		
	FY8PF15N-D3	FYD815SD3	FED-CNSL03 300 (11.8)	FED-CNML03 300 (11.8)	FYD-CNBL03 300 (11.8)	F-RC837	
			FED-CNSL05 500 (19.7)	FED-CNML05 500 (19.7)	FYD-CNBL05 500 (19.7)		
			FED-CNSL10 1000 (39.4)	FED-CNML10 1000 (39.4)	FYD-CNBL10 1000 (39.4)		